



# LE910C1/LE910C4 PSM Application Note

80502NT11758A Rev. 0 – 2019-06-19

**TELIT**  
TECHNICAL  
DOCUMENTATION

SPECIFICATIONS ARE SUBJECT TO CHANGE WITHOUT NOTICE

## **NOTICE**

While reasonable efforts have been made to assure the accuracy of this document, Telit assumes no liability resulting from any inaccuracies or omissions in this document, or from use of the information obtained herein. The information in this document has been carefully checked and is believed to be reliable. However, no responsibility is assumed for inaccuracies or omissions. Telit reserves the right to make changes to any products described herein and reserves the right to revise this document and to make changes from time to time in content hereof with no obligation to notify any person of revisions or changes. Telit does not assume any liability arising out of the application or use of any product, software, or circuit described herein; neither does it convey license under its patent rights or the rights of others.

It is possible that this publication may contain references to, or information about Telit products (machines and programs), programming, or services that are not announced in your country. Such references or information must not be construed to mean that Telit intends to announce such Telit products, programming, or services in your country.

## **COPYRIGHTS**

This instruction manual and the Telit products described in this instruction manual may be, include or describe copyrighted Telit material, such as computer programs stored in semiconductor memories or other media. Laws in the Italy and other countries preserve for Telit and its licensors certain exclusive rights for copyrighted material, including the exclusive right to copy, reproduce in any form, distribute and make derivative works of the copyrighted material. Accordingly, any copyrighted material of Telit and its licensors contained herein or in the Telit products described in this instruction manual may not be copied, reproduced, distributed, merged or modified in any manner without the express written permission of Telit. Furthermore, the purchase of Telit products shall not be deemed to grant either directly or by implication, estoppel, or otherwise, any license under the copyrights, patents or patent applications of Telit, as arises by operation of law in the sale of a product.

## **COMPUTER SOFTWARE COPYRIGHTS**

The Telit and 3rd Party supplied Software (SW) products described in this instruction manual may include copyrighted Telit and other 3rd Party supplied computer programs stored in semiconductor memories or other media. Laws in the Italy and other countries preserve for Telit and other 3rd Party supplied SW certain exclusive rights for copyrighted computer programs, including the exclusive right to copy or reproduce in any form the copyrighted computer program. Accordingly, any copyrighted Telit or other 3rd Party supplied SW computer programs contained in the Telit products described in this instruction manual may not be copied (reverse engineered) or reproduced in any manner without the express written permission of Telit or the 3rd Party SW supplier. Furthermore, the purchase of Telit products shall not be deemed to grant either directly or by implication, estoppel, or otherwise, any license under the copyrights, patents or patent applications of Telit or other 3rd Party supplied SW, except for the normal non-exclusive, royalty free license to use that arises by operation of law in the sale of a product.

## USAGE AND DISCLOSURE RESTRICTIONS

### I. License Agreements

The software described in this document is the property of Telit and its licensors. It is furnished by express license agreement only and may be used only in accordance with the terms of such an agreement.

### II. Copyrighted Materials

Software and documentation are copyrighted materials. Making unauthorized copies is prohibited by law. No part of the software or documentation may be reproduced, transmitted, transcribed, stored in a retrieval system, or translated into any language or computer language, in any form or by any means, without prior written permission of Telit

### III. High Risk Materials

Components, units, or third-party products used in the product described herein are NOT fault-tolerant and are NOT designed, manufactured, or intended for use as on-line control equipment in the following hazardous environments requiring fail-safe controls: the operation of Nuclear Facilities, Aircraft Navigation or Aircraft Communication Systems, Air Traffic Control, Life Support, or Weapons Systems (High Risk Activities"). Telit and its supplier(s) specifically disclaim any expressed or implied warranty of fitness for such High Risk Activities.

### IV. Trademarks

TELIT and the Stylized T Logo are registered in Trademark Office. All other product or service names are the property of their respective owners.

### V. Third Party Rights

The software may include Third Party Right software. In this case you agree to comply with all terms and conditions imposed on you in respect of such separate software. In addition to Third Party Terms, the disclaimer of warranty and limitation of liability provisions in this License shall apply to the Third Party Right software.

TELIT HEREBY DISCLAIMS ANY AND ALL WARRANTIES EXPRESS OR IMPLIED FROM ANY THIRD PARTIES REGARDING ANY SEPARATE FILES, ANY THIRD PARTY MATERIALS INCLUDED IN THE SOFTWARE, ANY THIRD PARTY MATERIALS FROM WHICH THE SOFTWARE IS DERIVED (COLLECTIVELY "OTHER CODE"), AND THE USE OF ANY OR ALL THE OTHER CODE IN CONNECTION WITH THE SOFTWARE, INCLUDING (WITHOUT LIMITATION) ANY WARRANTIES OF SATISFACTORY QUALITY OR FITNESS FOR A PARTICULAR PURPOSE.

NO THIRD PARTY LICENSORS OF OTHER CODE SHALL HAVE ANY LIABILITY FOR ANY DIRECT, INDIRECT, INCIDENTAL, SPECIAL, EXEMPLARY, OR CONSEQUENTIAL DAMAGES (INCLUDING WITHOUT LIMITATION LOST PROFITS), HOWEVER CAUSED AND WHETHER MADE UNDER CONTRACT, TORT OR OTHER LEGAL THEORY, ARISING IN ANY WAY OUT OF THE USE OR DISTRIBUTION OF THE OTHER CODE OR THE EXERCISE OF ANY RIGHTS GRANTED UNDER EITHER OR BOTH THIS LICENSE AND THE LEGAL TERMS APPLICABLE TO ANY SEPARATE FILES, EVEN IF ADVISED OF THE POSSIBILITY OF SUCH DAMAGES.

## APPLICABILITY TABLE

### PRODUCTS

- ■ LE910C1-NA
- ■ LE910C1-NS
- ■ LE910C1-NF
- ■ LE910C4-NF
- ■ LE910C1-EU
- ■ LE910C4-EU
- ■ LE910C1-AP
- ■ LE910C1-LA
- ■ LE910C4-LA
- ■ LE910C1-SV
- ■ LE910C1-SA
- ■ LE910C1-ST

## CONTENTS

### NOTICE 2

<b>COPYRIGHTS</b> .....	<b>2</b>
<b>COMPUTER SOFTWARE COPYRIGHTS</b> .....	<b>2</b>
<b>USAGE AND DISCLOSURE RESTRICTIONS</b> .....	<b>3</b>
<b>APPLICABILITY TABLE</b> .....	<b>4</b>
<b>CONTENTS</b> .....	<b>5</b>
<b>1. INTRODUCTION</b> .....	<b>6</b>
<b>2. OVERVIEW</b> .....	<b>8</b>
<b>3. PSM DESCRIPTION</b> .....	<b>9</b>
3.1. PSM Procedure Overview .....	9
3.2. PSM for LE910Cx .....	10
<b>4. EXTENDED DRX (EDRX)</b> .....	<b>12</b>
4.1. eDRX Procedure Overview .....	12
<b>5. HARDWARE CONTROLS</b> .....	<b>14</b>
5.1. LE910Cx pins related to PSM Mode .....	14
5.2. CONTROL PINS DESCRIPTION .....	14
5.2.1. ON_OFF_N (LE910Cx) .....	14
5.2.2. VAUX/PWRMON .....	15
5.2.3. HW_SHUTDOWN* .....	15
5.3. SIM interface .....	15
5.4. PSM configuration .....	15
5.5. Hardware application example .....	16
<b>6. GLOSSARY AND ACRONYMS</b> .....	<b>17</b>
<b>7. DOCUMENT HISTORY</b> .....	<b>18</b>

## 1. INTRODUCTION

### 1.1. Scope

The LE910Cx includes unique advanced features in order to support the PSM according to 3GPP Rel-12.

The aim of this document is the description of the suggested Application design to use this functionality.

### 1.2. Audience

This document is intended for Telit customers, who are integrators, about to implement their applications using our LE910Cx modules.

### 1.3. Contact Information, Support

For general contact, technical support services, technical questions and report documentation errors contact Telit Technical Support at:

- TS-EMEA@telit.com
- TS-AMERICAS@telit.com
- TS-APAC@telit.com

Alternatively, use:

<http://www.telit.com/support>

For detailed information about where you can buy the Telit modules or for recommendations on accessories and components visit:

<http://www.telit.com>

Our aim is to make this guide as helpful as possible. Keep us informed of your comments and suggestions for improvements.

Telit appreciates feedback from the users of our information.

## 1.4. Text Conventions

---



Danger – This information **MUST** be followed or catastrophic equipment failure or bodily injury may occur.

---

---



Caution or Warning – Alerts the user to important points about integrating the module, if these points are not followed, the module and end user equipment may fail or malfunction.

---

---



Tip or Information – Provides advice and suggestions that may be useful when integrating the module.

---

All dates are in ISO 8601 format, i.e. YYYY-MM-DD.

## 1.5. Related Documents

- LE910Cx HW User Guide, 1VV0301298
- LE910Cx AT\_Commands\_Reference\_Guide\_R2, 80502ST10950A
- Telit EVB User Guide, 1VV0301249

## 2. OVERVIEW

The aim of this document is the description of some hardware solutions useful for developing a product with the Telit LE910Cx module.

In this document all the basic functions of a mobile phone will be taken into account; for each one of them a proper hardware solution will be suggested and eventually the wrong solutions and common errors to be avoided will be evidenced. Obviously, this document cannot embrace the whole hardware solutions and products that may be designed. The wrong solutions to be avoided shall be considered as mandatory, while the suggested hardware configurations shall not be considered mandatory, instead the information given shall be used as a guide and a starting point for properly developing your product with the Telit LE910Cx module. For further hardware details that may not be explained in this document refer to the Telit LE910Cx Product Description document where all the hardware information is reported.



### NOTICE:

(EN) The integration of the LTE **LE910Cx** cellular module within user application shall be done according to the design rules described in this manual.

(IT) L'integrazione del modulo cellulare LTE **LE910Cx** all'interno dell'applicazione dell'utente dovrà rispettare le indicazioni progettuali descritte in questo manuale.

(DE) Die Integration des **LE910Cx** LTE Mobilfunk-Moduls in ein Gerät muß gemäß der in diesem Dokument beschriebenen

Konstruktionsregeln erfolgen.

(SL) Integracija LTE **LE910Cx** modula v uporabniški aplikaciji bo morala upoštevati projektna navodila, opisana v tem priročniku.

(SP) La utilización del modulo LTE **LE910Cx** debe ser conforme a los usos para los cuales ha sido diseñado descritos en este manual del usuario.

(FR) L'intégration du module cellulaire LTE **LE910Cx** dans l'application de l'utilisateur sera faite selon les règles de conception décrites dans ce manuel.

(HE) האינטגרציה של המודול **LE910Cx** לתוך המערכת של המשתמש תיעשה לפי הכללים המפורטים במסמך זה. אין המצור.

The information presented in this document is believed to be accurate and reliable. However, no responsibility is assumed by Telit Communications S.p.A. for its use, nor any infringement of patents or other rights of third parties which may result from its use. No license is granted by implication or otherwise under any patent rights of Telit Communications S.p.A. other than for circuitry embodied in Telit products. This document is subject to change without notice.



### 3. PSM DESCRIPTION

#### 3.1. PSM Procedure Overview

The Power Saving Mode (PSM) in 3GPP Rel12 allows the Module to skip idle mode tasks for a longer time period while still maintaining the NAS context. The functionality is available on M1/NB1 on the LE910Cx Series.

This feature permits to reduce the overall power consumption when there is no required data activity with the network for a long time.

This saves the power also related to the Paging activity.

The PSM reduces the signaling load between the LE910Cx and the network on NAS level (24.301 Rel.12 chapter 5.3.11) compared to a standard attach/detach procedure.

Within the attach/RAU/TAU procedure the UE indicates that it supports PSM and the network confirms/accepts PSM usage by sending two different timers (T3324 and T3412 extended Value) in the confirmation message.

The timer T3324 specifies an active period after the RAU/TAU procedure the UE has to follow the normal idle mode procedures (paging reception, measurements,...).

After timer T3324 expires the Module enters PSM state, i.e. it disables all AS/NAS activities until the next periodic RAU/TAU update.

Timer T3412 extended value is defining the time between two subsequent RAU/TAU procedures and starts together with T3324. This implies that the time in which the module will be NOT reachable by the network (inactivity period) is given by T3412\_ext - T3324.

Before the inactivity period starts the complete NAS context needs to be stored and reused when accessing the network again.

The Module can leave the PSM mode at any point in time when there is MO data or when periodic TAU timer expires.

The PSM is only intended for those Modules that can tolerate a high MT Call latency.

The 3GPP standard does not specify current limits to be satisfied or power reduced to when PSM is used by the module. Only the signaling reduction (i.e. Not doing a reattach but just a RAU/TAU procedure) is defined.

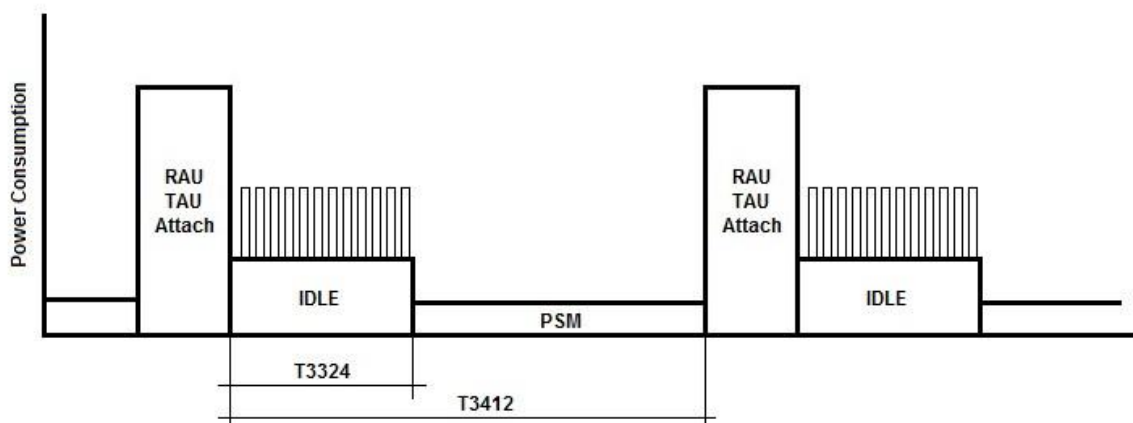

### 3.2. PSM for LE910Cx

LE910Cx implements PSM features and allows the user to activate PSM by sending the specific AT command AT+CPSMS as described in [x] AT Command User Guide

As soon as PSM has been accepted by the network (i.e. Timers have been received in TAU Accept message) T3324 starts and LE910 is in IDLE state with default module functionality.

Since default functionality for LE910Cx (and all Telit modules) is CFUN=1 the current absorption for the module will be equal to standard idle CFUN=1 state and around 22 mA.

As T3324 expires the module enters the PSM state which is basically an OFF state with RTC running in the background bringing the current consumption level to around 7.7 uA.

Users willing to decrease the power consumption during T3324 can combine AT+CFUN states (e.g. AT+CFUN=5 and Asserting low the DTR pin) with PSM as shown in the below figures.

When AT+CFUN=5 is used during T3324 the specific functionality allows to save current still keeping module synchronized and reachable the network.

[ PSM activation and CFUN=1 (default) ]

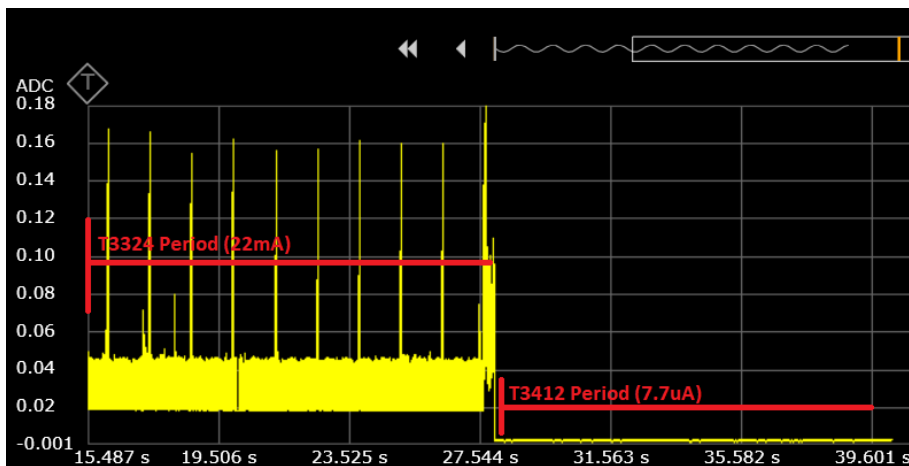

[ PSM activation and CFUN=5 ]

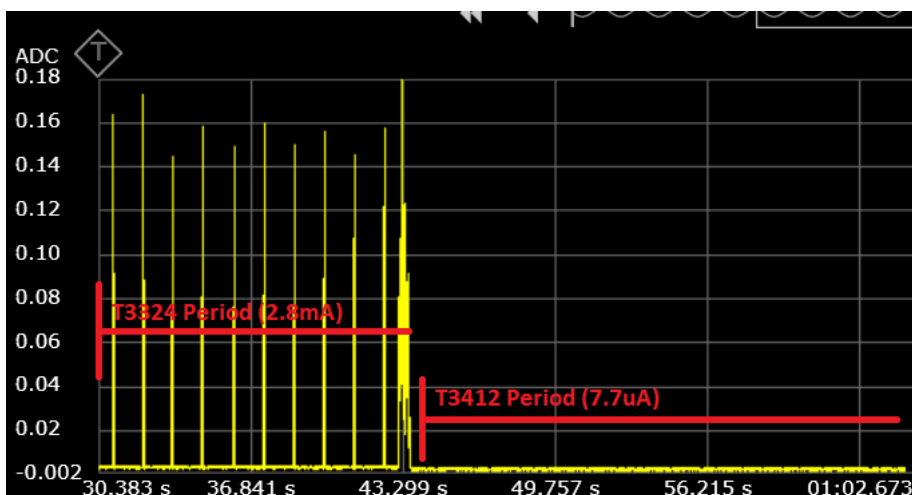

An example of command to activating PSM for LE910Cx is as follows:

```
AT+CPSMS=1,,," & T3412 & "," & T3324
```

```
T3412= 10000011 -> 90 sec
```

```
T3324= 00001010 -> 20 sec
```

With these settings the module will send TAU every 90 sec and will stay IDLE for 20 sec. This is true when using a network simulator because in a real environment the final decision of which timers have to be applied is taken by the network that can accept the proposed timers or decide to send its own timers. If different timers are sent back by the network then DUT must apply the Network timers.

The nature of PSM and the current consumption profile suggest that the major efficiency is achieved when T3412 is longer than 5-6 hours.

If an application cannot support modules being out of connection for so long but it is still willing to reduce power then eDRX feature should be evaluated.



*Telit implementation of PSM includes a SW check that avoids UE to enter PSM mode if the settings of T3412 and T3324, are such that the next wake up would happen before a preconfigured minimum time duration 60s.*

**As a result of this check the following precondition will need to be verified for the PSM to be activated :  $T3412 - T3324 > 60$  sec**

*The above is to avoid an incorrect use of PSM resulting in higher current consumption due to shut down and reboot compared to the current consumption in idle state in 60s.*

---

## 4. EXTENDED DRX (EDRX)

### 4.1. eDRX Procedure Overview

extended DRX (eDRX) is an extension of the discontinuous reception (DRX). DRX is a technic used during RRC IDLE to reduce UE power consumption that periodically listen to the paging channel and sleep in between two different paging listening events.

eDRX tries to enhance the power consumption increasing the sleeping period, but this has to be done in coordination with the network that will know about this extension and will cache paging requests directed to the UE. eDRX features defines to different timers

**Paging Time Window (PTW)** : the window in which the UE will behaves in DRX mode

**eDRX cycle** : the time between the start of two different and subsequent time windows these two timers are exchanged between UE and Network by means of Attach or TAU/RAU Accept message.

When eDRX is activated by means of the specific command the DRX activity is stopped for a longer period and the module remains in sleep and not listening the paging channel anymore till the end of the eDRX cycle. In other words, the UE will not be reachable from the network from the end of the PTW to the end of the eDRX cycle.

Below is a picture that explain the differences between DRX and eDRX.

Fig 1. DRX vs eDRX comparison

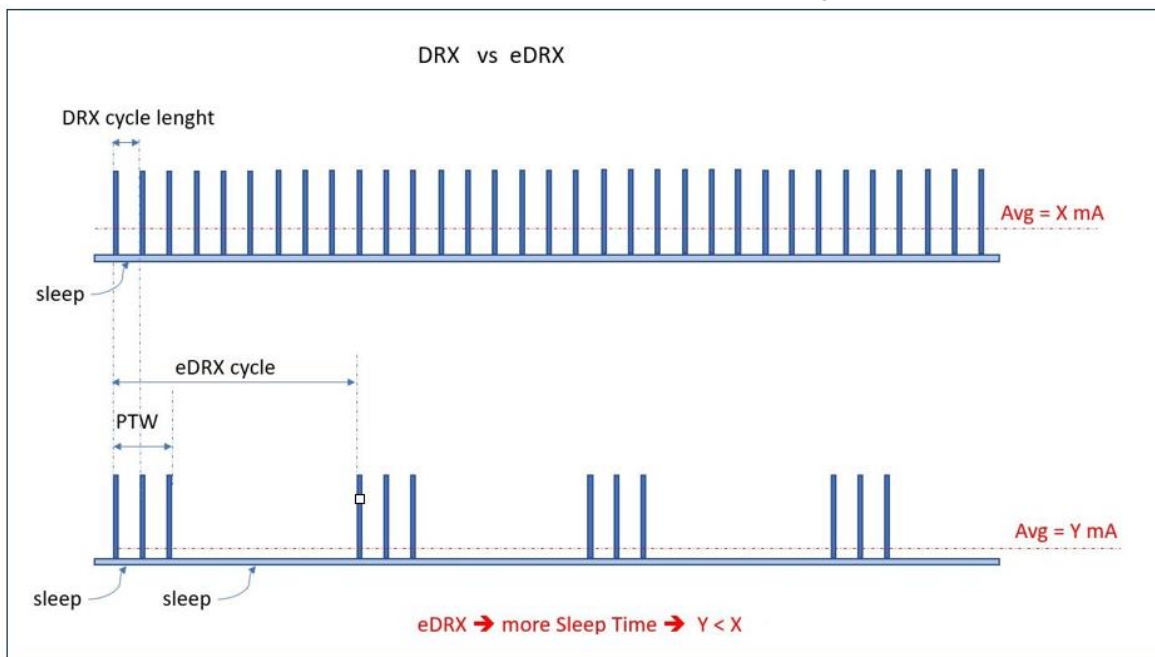

The default value of PTW and eDRX cycle are like below.

PTW : 6400 eDRX : 1024

The value of eDRX cycle can be set by following command (see AT command user guide for detailed definition).

```
AT+CEDRXS=1,4,"0001"
```

Even if the module supports specific eDRX and PTW values, the different values supported by the NW can be sent to UE through the Attach accept and TAU accept messages. In some cases, eDRX is not supported by NW. This can be confirmed by the below command. (see AT command user guide for detailed definition).

```
AT+CEDRXRDP
```

Regarding the current profile for eDRX and LE910Cx, the sleep current related on paging occurrence and long sleep has a value of around 1.1~1.2mA so that allows to be reduced by as much as 0.2-0.3 mA when eDRX is used with AT+CFUN=5.

eDRX is a different procedure in respect PSM that is practically OFF when PSM is activated but has to pay in terms of consumption to wake up from PSM because a BOOT+CAMP+ TAU is needed.

That means that there is a breakeven point that suggest to use eDRX for applications that requires the module to be available very often and in any case at maximum every few hours, if the module can sleep more time the PSM feature must be evaluated because it could be more efficient from power consumption point of view.

**Note.** *PSM and eDRX are not mutually exclusive and can work together. If PSM and eDRX are applied at the same time eDRX will basically work during the PSM idle time reducing the power consumption within the T3324.*

## 5. HARDWARE CONTROLS

### 5.1. LE910Cx pins related to PSM Mode

Pin Signal	I/O Function	Type	Comment
R12 ON_OFF_N	I Input command for power ON and to wake from deep sleep mode		Active low, connected to open drain or open collector
R11 VAUX PWRMON	O 1.8V LDO output Power ON monitor	Supply 1.8V	
R13 HW_SHUTDOWN	I HW Unconditional Shutdown		Active low, connected to open drain or open collector

### 5.2. CONTROL PINS DESCRIPTION

#### 5.2.1. ON\_OFF\_N (LE910Cx)

ON\_OFF\_N is the pin that turns on the system after VBATT and VBATT\_PA is applied to LE910Cx. Moreover, this pin can make an asynchronous wakeup of the system from the PSM Mode, before the scheduled event of timer T3412 expired.

To make asynchronous exit from PSM mode ON\_OFF\_N pin must be set LOW for at least 5 seconds.



#### NOTE:

Don't use any pull up resistor on the ON\_OFF\_N line, it is internally pulled up. Using pull up resistor may bring to latch up problems on the LE910Cx power regulator and improper power on/off of the module. The line ON\_OFF\_N must be connected only in open collector or open drain configuration.

### 5.2.2. VAUX/PWRMON

There is no pin dedicated to PSM status indicator, host can only detect deep sleep mode by monitoring of VAUX/PWRMON output pin.

### 5.2.3. HW\_SHUTDOWN\*

During PSM mode, HW\_SHUTDOWN toggle has no effect. The use of HW\_SHUTDOWN\* pin is valid only when LE910Cx has VAUX/PWRMON output HI.

## 5.3. SIM interface

SIM interface is powered down when LE910Cx enters in PSM mode to ensure minimal power consumption

For this reason SIM PIN, if enabled, should be managed in every scheduled wake, or can simply be disabled.

## 5.4. PSM configuration

PSM has to be configured by the command AT+CPSMS.

The command controls whether the UE wants to apply PSM or not, as well as the requested extended periodic RAU value and the requested GPRS READY timer value in GERAN/UTRAN, the requested extended periodic TAU value in E-UTRAN and the requested Active Time value.

Examples:

AT+CPSMS=0 → disable the use of PSM

AT+CPSMS=1,,,"10100010","00100001" → PSM Mode is set to enabled and module enters in PSM after a minute (T3324 = 33) and stay in this mode for two minute (T3412 = 162).

For additional details on AT+CPSMS command please refer to the LE910Cx AT commands Reference Guide

When Periodic Update Timer expires (T3324), LE910Cx turns off until the next scheduled wake-up time.

5.5. Hardware application example

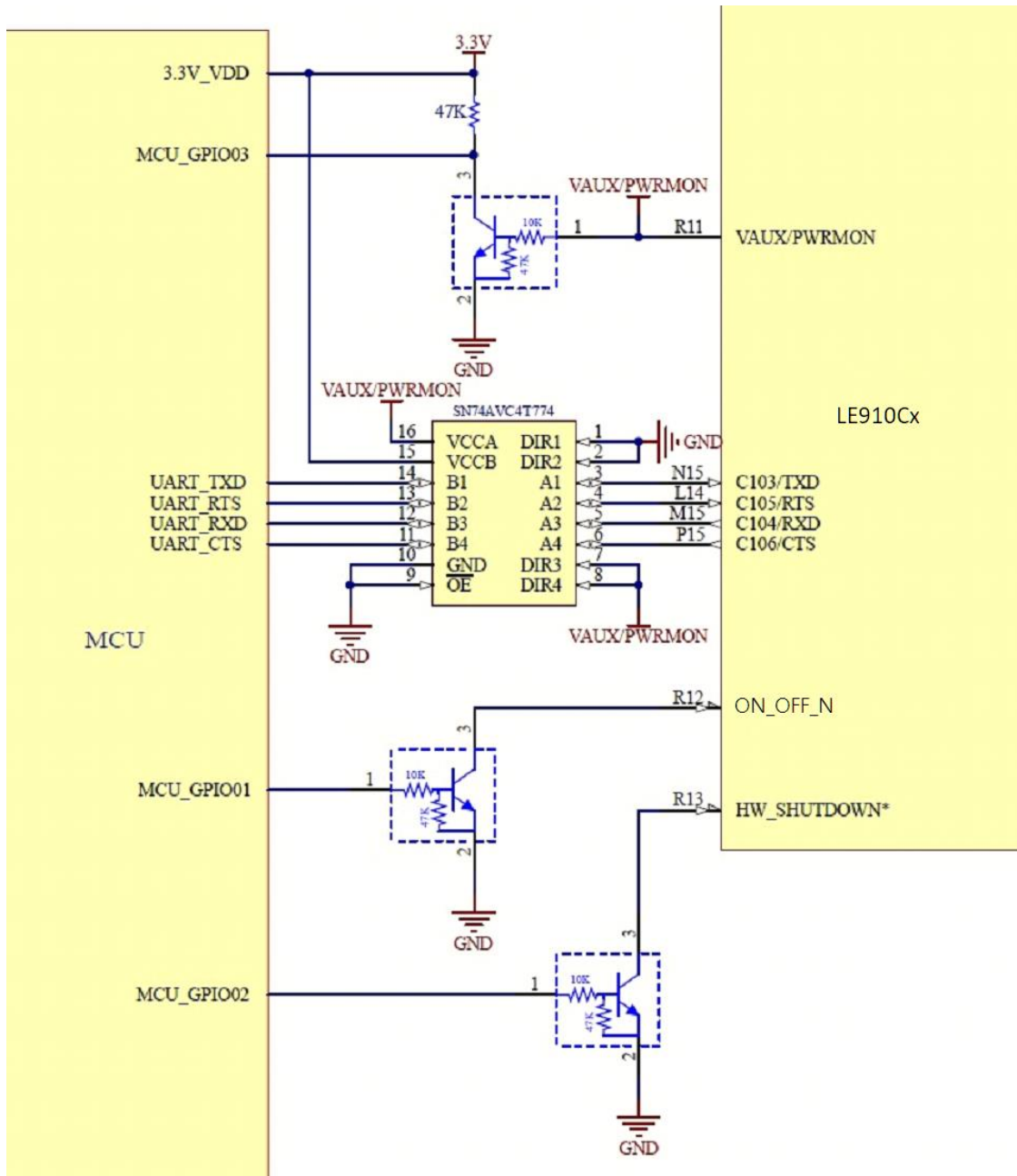



## 6. GLOSSARY AND ACRONYMS

	Description
TTSC	Telit Technical Support Centre
USB	Universal Serial Bus
HS	High Speed
DTE	Data Terminal Equipment
LTE	Long Term Evolution
PSM	Power Saving Mode according to 3GPP Rel.12
AS	Access Stratum
NAS	Non-Access Stratum
RAU	Routing Area Update
TAU	Tracking Area Update
HSIC	High Speed Inter Chip
SIM	Subscriber Identification Module
SPI	Serial Peripheral Interface
ADC	Analog – Digital Converter
DAC	Digital – Analog Converter
I/O	Input Output
GPIO	General Purpose Input Output
CMOS	Complementary Metal – Oxide Semiconductor
CLK	Clock
MRDY	Master Ready
SRDY	Slave Ready
CS	Chip Select
RTC	Real Time Clock
PCB	Printed Circuit Board
ESR	Equivalent Series Resistance
VSWR	Voltage Standing Wave Ratio
VNA	Vector Network Analyzer

## 7. DOCUMENT HISTORY

---

Revision	Date	Changes
0	2019-06-19	First issue



# SUPPORT INQUIRIES

Link to [www.telit.com](http://www.telit.com) and contact our technical support team for any questions related to technical issues.

[www.telit.com](http://www.telit.com)



Telit Communications S.p.A.  
Via Stazione di Prosecco, 5/B  
I-34010 Sgonico (Trieste), Italy

Telit Wireless Solutions Inc.  
3131 RDU Center Drive, Suite 135  
Morrisville, NC 27560, USA

Telit Wireless Solutions Ltd.  
10 Habarzel St.  
Tel Aviv 69710, Israel

Telit IoT Platforms LLC  
5300 Broken Sound Blvd, Suite 150  
Boca Raton, FL 33487, USA

Telit Wireless Solutions Co., Ltd.  
8th Fl., Shinyoung Securities Bld.  
6, Gukjegeumyung-ro8-gil, Yeongdeungpo-gu  
Seoul, 150-884, Korea

Telit Wireless Solutions  
Tecnologia e Servicos Ltda  
Avenida Paulista, 1776, Room 10.C  
01310-921 São Paulo, Brazil

Telit reserves all rights to this document and the information contained herein. Products, names, logos and designs described herein may in whole or in part be subject to intellectual property rights. The information contained herein is provided "as is". No warranty of any kind, either express or implied, is made in relation to the accuracy, reliability, fitness for a particular purpose or content of this document. This document may be revised by Telit at any time. For most recent documents, please visit [www.telit.com](http://www.telit.com)

Copyright © 2016, Telit

2019-06 Rev.1